



# SMART Transmitter Power Supply HiC2025

- 1-channel isolated barrier
- 24 V DC supply (bus powered)
- Input for 2-wire SMART transmitters and current sources
- Output for 4 mA ... 20 mA or 1 V ... 5 V
- Low power dissipation
- Up to SIL 2 (SC 3) acc. to IEC/EN 61508



## Function

This isolated barrier is used for intrinsic safety applications. The device supplies 2-wire transmitters in the hazardous area, and can also be used with current sources. It transfers the analog input signal to the safe area as an isolated current value. Bi-directional communication is supported for SMART transmitters that use current modulation to transmit data and voltage modulation to receive data. The output is selected as a current source, current sink, or voltage source via DIP switches. This device mounts on a HiC Termination Board.

## Application

The device supports the following SMART protocols:

- HART
- BRAIN

## Connection

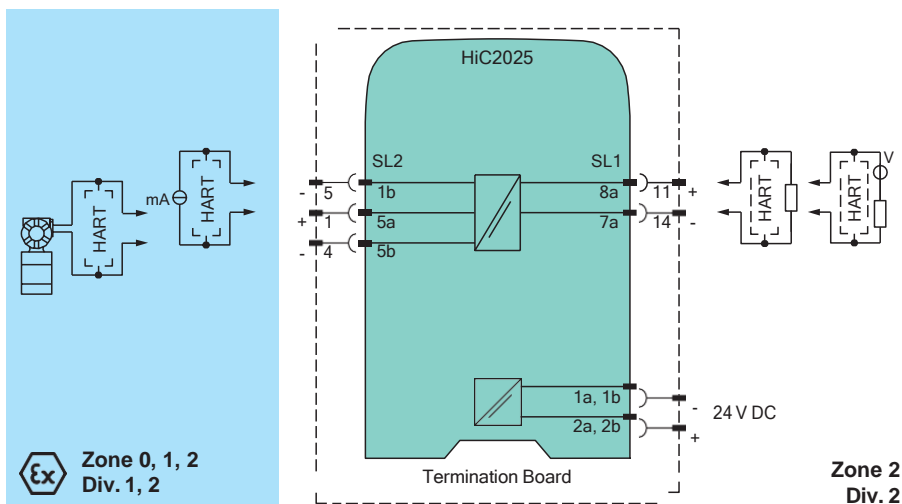

## Technical Data

## General specifications

Signal type

Analog input

Refer to "General Notes Relating to Pepperl+Fuchs Product Information".

Pepperl+Fuchs Group  
www.pepperl-fuchs.com

Iran: +9821 91007267  
[info@omranniroo.com](mailto:info@omranniroo.com)

Germany: +49 621 776 2222  
[pa-info@de.pepperl-fuchs.com](mailto:pa-info@de.pepperl-fuchs.com)

Singapore: +65 6779 9091  
[pa-info@sg.pepperl-fuchs.com](mailto:pa-info@sg.pepperl-fuchs.com)



**Functional safety related parameters**

Safety Integrity Level (SIL)		SIL 2
Systematic capability (SC)		SC 3

**Supply**

Connection		SL1: 1a, 1b(-); 2a, 2b(+)
Rated voltage	$U_r$	19 ... 30 V DC bus powered via Termination Board
Ripple		$\leq 10 \%$
Rated current	$I_r$	$\leq 45 \text{ mA}$ at 24 V and 20 mA source mode output
Power dissipation		$\leq 800 \text{ mW}$
Power consumption		$\leq 1.1 \text{ W}$

**Input**

Connection side		field side
Connection		SL2: 5a(+), 1b(-); 5a(+), 5b(-)
Input signal		4 ... 20 mA limited to approx. 26 mA
Voltage drop		approx. 5 V on SL2: 5a(+), 1b(-)
Available voltage		$\geq 15 \text{ V}$ at 20 mA, $\geq 18 \text{ V}$ at 4 mA on SL2: 5a(+), 5b(-)

**Output**

Connection side		control side
Connection		SL1: 8a(+), 7a(-)
Load		0 ... 350 $\Omega$ (source mode)
Output signal		source mode: 4 ... 20 mA or 1 ... 5 V (internal resistor: 250 $\Omega$ , 0.1 %) sink mode: 4 ... 20 mA, operating voltage 10 ... 30 V For additional internal or external loads the voltage drop has to be considered, e. g. 250 $\Omega$ x 20 mA = 5 V.
Ripple		20 mV <sub>rms</sub>

**Transfer characteristics**

Deviation		at 20 °C (68 °F) $< 0.1 \%$ of full scale, incl. non-linearity and hysteresis (source mode and sink mode 4 ... 20 mA) $\leq \pm 0.2 \%$ incl. non-linearity and hysteresis (source mode 1 ... 5 V)
Influence of ambient temperature		$< 2 \mu\text{A/K}$ (-20 ... 70 °C (-4 ... 158 °F)); $< 4 \mu\text{A/K}$ (-40 ... -20 °C (-40 ... -4 °F)) (source mode and sink mode 4 ... 20mA) $< 0.5 \text{ mV/K}$ (-20 ... 70 °C (-4 ... 158 °F)); $< 1 \text{ mV/K}$ (-40 ... -20 °C (-40 ... -4 °F)) (source mode 1...5 V)
Frequency range		field side into the control side: bandwidth with 0.5 V <sub>pp</sub> signal 0 ... 3 kHz (-3 dB) control side into the field side: bandwidth with 0.5 V <sub>pp</sub> signal 0 ... 3 kHz (-3 dB)
Settling time		$\leq 50 \text{ ms}$
Rise time/fall time		$\leq 10 \text{ ms}$

**Galvanic isolation**

Input/Output		safe electrical isolation acc. to IEC/EN 60079-11, voltage peak value 375 V
Input/power supply		safe electrical isolation acc. to IEC/EN 60079-11, voltage peak value 375 V
Output/power supply		basic insulation according to IEC/EN 61010-1, rated insulation voltage 60 V <sub>eff</sub>

**Indicators/settings**

Display elements		LED
Control elements		DIP switch
Configuration		via DIP switches
Labeling		space for labeling at the front

**Directive conformity**

Electromagnetic compatibility		
Directive 2014/30/EU		EN 61326-1:2013 (industrial locations)

**Conformity**

Electromagnetic compatibility		NE 21:2017 EN 61326-3-2:2018 For further information see system description.
Degree of protection		IEC 60529:2001
Protection against electrical shock		UL 61010-1:2012

**Ambient conditions**

## Technical Data

Ambient temperature	-40 ... 70 °C (-40 ... 158 °F)		
<b>Mechanical specifications</b>			
Degree of protection	IP20		
Mass		approx. 100 g	
Dimensions		12.5 x 106 x 128 mm (0.5 x 4.2 x 5.1 inch) (W x H x D)	
Mounting		on termination board	
Coding		pin 1 and 3 trimmed For further information see system description.	
<b>Data for application in connection with hazardous areas</b>			
EU-type examination certificate	CESI 06 ATEX 017		
Marking		1 II (1)G [Ex ia Ga] IIC 1 II (1)D [Ex ia Da] IIIC 1 I (M1) [Ex ia Ma] I	
Input		Ex ia	
Supply			
Maximum safe voltage	U <sub>m</sub>	250 V AC (Attention! U <sub>m</sub> is no rated voltage.)	
Equipment		SL2: 5a(+), 5b(-)	
Voltage	U <sub>o</sub>	25.2 V	
Current	I <sub>o</sub>	100 mA	
Power	P <sub>o</sub>	630 mW	
Internal capacitance	C <sub>i</sub>	5.7 nF	
Internal inductance	L <sub>i</sub>	negligible	
Equipment		SL2: 5a(+), 1b(-)	
Voltage	U <sub>i</sub>	30 V	
Current	I <sub>i</sub>	128 mA	
Voltage	U <sub>o</sub>	7.2 V	
Current	I <sub>o</sub>	100 mA	
Power	P <sub>o</sub>	25 mW	
Internal capacitance	C <sub>i</sub>	5.7 nF	
Internal inductance	L <sub>i</sub>	negligible	
Certificate		CESI 19 ATEX 027 X	
Marking		1 II 3G Ex ec IIC T4 Gc	
Directive conformity			
Directive 2014/34/EU		EN 60079-0:2012+A11:2013 , EN 60079-11:2012 , EN 60079-7:2015	
<b>International approvals</b>			
FM approval			
FM certificate		FM 19 US 0122 X , FM 19 CA 0065 X	
Control drawing		116-0470 (cFMus)	
UL approval		E106378	
Control drawing		116-0458 (cULus)	
IECEx approval			
IECEx certificate		IECEx CES 06.0002X	
IECEx marking		[Ex ia Ga] IIC , [Ex ia Da] IIIC , [Ex ia Ma] I Ex ec IIC T4 Gc	
<b>General information</b>			
Supplementary information		Observe the certificates, declarations of conformity, instruction manuals, and manuals where applicable. For information see <a href="http://www.pepperl-fuchs.com">www.pepperl-fuchs.com</a> .	

## Assembly

Front view

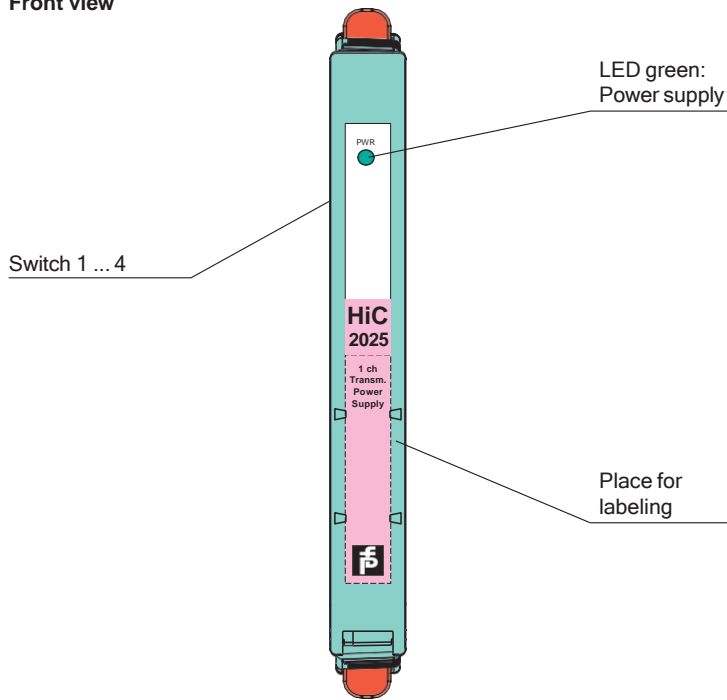

## Configuration

Configure the device in the following way:

- Push the red Quick Lok Bars on each side of the device in the upper position.
- Remove the device from termination board.
- Set the switches according to the figure in the **Configuration** section.

### Note

The pins for this device are trimmed to polarize it according to its safety parameters. Do not change the setting. For further information see system description.

**Configuration**

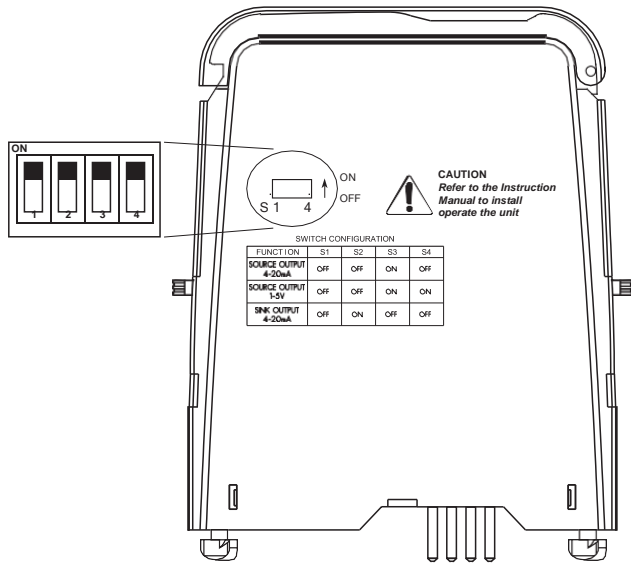

**Switch position**

Function	S1	S2	S3	S4
Current source 4 mA ... 20 mA	OFF	OFF	ON	OFF
Voltage source 1 V ... 5 V	OFF	OFF	ON	ON
Current sink 4 mA ... 20 mA	OFF	ON	OFF	OFF

Factory setting: current source 4 mA ... 20 mA